



DP20N3
DP25N3
DP30N3
DP35N3

GP15N
GP18N
GP20CN
GP20N
GP25N
GP30N
GP35N

**DURABLE,
CONSISTENT, RUGGED**

SPECIFICATIONS

ENGINE POWERED LIFT TRUCKS 1.5 - 3.5 TONNES



DURABLE, CONSISTENT, RUGGED...

OUR RANGE OF SMALLER ENGINE-POWERED TRUCKS OFFERS AN EXCELLENT BLEND OF POWER AND PERFORMANCE WITH THE ADVANTAGE OF LOW FUEL CONSUMPTION - FOR EASY AND ECONOMICAL USE.



With a variety of load capacities, frame types, mast designs and engine sizes to choose from, you can be sure of the ideal configuration to suit your needs.

Ideal for industrial applications, the trucks achieve outstanding traction on sloping or slippery surfaces, with solid pneumatic tyres also providing excellent operator comfort.



Our latest Stage V diesel engine, with its advanced exhaust gas technology, meets stringent EU regulations. Its built-in warning system and easy maintenance procedures help to keep your lift truck in service and minimise your costs.



A wide range of optional features allows you to match the specification of your Cat® lift truck to your application. A double air filter, for example, can be fitted to provide increased engine protection in dusty applications such as in mills and brickyards, while optional lifting eyes can be attached to enable hoisting of the truck onto a ship or lorry for port-based or mobile use.

LOWER COST OF OWNERSHIP

- Modern design techniques in combination with long component life result in a long service interval which reduces total cost of ownership.
- Vehicle Control Module manages various truck and operator functions, allowing easy troubleshooting and pinpointing of problems.
- LCD display provides extensive information on truck operation, maintenance state and soot level (diesel) - with indication of service requirements to prevent unexpected downtime and costs due to unscheduled servicing and repairs.
- LED front work lights and front/rear combination lights reduce energy consumption and maintenance costs.
- Robust and durable chassis is fitted with full belly guard to protect engine compartment from dust, water and dirt.

UNMATCHED PRODUCTIVITY

- Powerful, proven industrial engine offers state-of-the-art LPG technology, including electronic engine management system and 3-way catalytic converter, for great performance, low noise and emission levels, and efficient fuel usage.
- Fully floating powertrain layout lowers centre of gravity, increases truck stability and maximises residual lifting capacities.
- Reliable, high performance, electronically controlled Stage V diesel engine delivers low emission levels with low fuel consumption.
- Compact design means this range is also suitable for use in aisles with tight spaces.
- Mast carriage features six bearings, increasing durability and lifting speed, while powerful hydraulic system offers high residual capacities for easy handling of heavier loads.
- Optional factory-fitted panel cabin keeps the elements out, without compromising visibility, combining form and function in a design which keeps the truck performing in the most extreme of temperatures and in wet environments.

SAFETY AND ERGONOMICS

- Presence Detection System (PDS) prevents truck operation when operator is not seated.
- Low noise levels combine with the ergonomic and comfortable Grammer seat to help maintain operator concentration and reduce fatigue during long shifts.
- Fingertip hydraulic controls are mounted on a fully adjustable armrest for optimum load handling and easy manoeuvrability.
- Automotive-style pedal layout allows easy and comfortable operation.
- Adjustable steering column with memory position can be set according to operator's preference for comfortable operation.
- Low step in chassis enables easy on and off access.
- Good all-round visibility and ergonomic layout of all controls improves comfort and minimises operator fatigue.
- Hand grip mounted at the rear of the overhead guard, with a horn button, increases safety and reduces back strain and fatigue in applications involving repetitive reversing.



STANDARD EQUIPMENT AND OPTIONS

GENERAL	DIESEL		LP GAS			
	DP20-25N3	DP30-35N3	GP15-18N	GP20CN	GP20-25N	GP30-35N
Dust proof kit	○	○	○	○	○	○
Line filter for torque converter	○	○	○	○	○	○
Universal joint cover powertrain	○	○	○	○	○	○
LPG bracket removed	-	-	○	○	○	○
LPG Swing down bracket, no tank	-	-	○	○	○	○
Tilt cylinder boot kit	-	-	-	-	-	-
Belly plate (under cover)	●	●	●	●	●	●
Large capacity battery	-	-	○	○	○	○
Fire extinguisher	○	○	○	○	○	○
Equipment Bar	○	○	○	○	○	○
HYDRAULIC						
3-way control valve MC	●	●	●	●	●	●
3-way control valve FC	○	○	○	○	○	○
4-way control valve MC	○	○	○	○	○	○
4-way control valve FC	○	○	○	○	○	○
5-way control valve MC	○	○	-	-	○	○
5-way control valve FC	○	○	-	-	○	○
Automatic tilt centering via the F2 button on fingertip controller	○	○	○	○	○	○
F2 Double action button for clamp release (*cannot be combined with Tilt Horizontal control)	○	○	○	○	○	○
Hydraulic accumulator	○	○	-	-	○	○
MAST, FORKS AND CARRIAGE						
Loose mast	○	○	○	○	○	○
Heavy Load side roller (*Cannot be combined with an integral sideshifter)	○	○	○	○	○	○
Side shifter 920 mm	-	-	○	○	-	-
Side shifter 1000 mm	○	○	-	-	○	○
Integral side shifter 920 mm	-	-	○	○	-	-
Integral side shifter 1000 mm	○	○	-	-	○	○
Hook-on Side shifting Fork Positioner 920 mm	○	○	○	-	○	○
Hook-on Side shifting Fork Positioner 1000 mm	○	○	○	-	○	○
Fork deletion	○	○	○	○	○	○
ELECTRIC						
Backup handle with horn button	●	●	●	●	●	●
Electric diesel control (Diesel)	●	●	○	○	○	○
Speed control system (LPG)	-	-	○	○	○	○
Indicator kit	○	○	○	○	○	○
LED light set	●	●	●	●	●	●
LED rear work light	○	○	○	○	○	○
Load weight indicator (for simplex & triplex masts)	●	●	○	○	○	○
Strobe light (orange)	○	○	○	○	○	○
FNR switch on adjustable armrest * (*Standard on FC models)	○	○	○	○	○	○
"Blue point" rear light	○	○	○	○	○	○
USB port	○	○	○	○	○	○

● Standard ○ Option

Contact your dealer for additional standard and optional equipment.

STANDARD EQUIPMENT AND OPTIONS (CONTINUED)

	DIESEL		LP GAS			
	DP20-25N3	DP30-35N3	GP15-18N	GP20CN	GP20-25N	GP30-35N
OHG AND CABIN						
Grammer MSG 65 Vinyl seat	●	●	●	●	●	●
Grammer MSG 65 Cloth seat	○	○	○	○	○	○
Grammer MSG 65 with heater	○	○	○	○	○	○
Rear view mirrors (not available with Deluxe Cabin)	●	●	●	●	●	●
Tilt steering column with memory position	○	○	○	○	○	○
Convenience tray (* not available for FC models)	○	○	-	-	○	○
Deluxe Cabin	○	○	-	-	○	○
Panel cabin Front screen with wiper + roof	○	○	-	-	○	○
Panel cabin rear screen	○	○	-	-	○	○
Panel cabin PVC doors, LH & RH	○	○	-	-	○	○
Panel cabin steel doors	○	○	-	-	○	○
TYRES						
Solid pneumatic tyres	●	●	●	●	●	●
Pneumatic tyres	○	○	○	-	○	○
Solid pneumatic dual drive tyres	○	○	-	-	○	○
Pneumatic dual drive tyres	○	○	-	-	○	○
Non-marking solid tires	○	○	○	○	○	○
ENVIRONMENT						
Single element air cleaner	●	●	-	-	-	-
Double element air cleaner	○	○	●	●	●	●
Elevated exhaust	○	○	○	○	○	○



● Standard ○ Option

Contact your dealer for additional standard and optional equipment.

Characteristics			Cat Lift Trucks	Cat Lift Trucks	Cat Lift Trucks	Cat Lift Trucks
Weight						
1.1	Manufacturer (abbreviation)		DP20N3	DP25N3	DP30N3	DP35N3
1.2	Manufacturer's model designation		Diesel	Diesel	Diesel	Diesel
1.3	Power source: (battery, diesel, LPG, petrol)		Seated	Seated	Seated	Seated
1.4	Operator type: pedestrian, (operator) - standing, - seated		2000	2500	3000	3500
1.5	Load capacity	Q (kg)	500	500	500	500
1.6	Load centre distance	c (mm)	455	460	495	495
1.8	Load distance, axle to fork face	x (mm)	1600	1600	1700	1700
1.9	Wheelbase	y (mm)				
Wheels, Drive Train						
2.1	Truck weight, without load / including battery (simplex mast, lowest lift height)	kg	SE / SE	SE / SE	SE / SE	SE / SE
2.2	Axle loading with maximum load, front / rear (simplex mast, lowest lift height)	kg	7.00-12-12PR	7.00-12-12PR	28x9-15-12PR	250-15-12PR
2.3	Axle loading without load, front / rear (simplex mast, lowest lift height)	kg	6.00-9-10PR	6.00-9-10PR	6.50-10-10PR	6.50-10-10PR
Dimensions						
3.1	Tyres: V = solid, L = pneumatic, SE = solid pneumatic - front / rear		2x / 2	2x / 2	2x / 2	2x / 2
3.2	Tyre dimensions, front		960	960	1060	1060
3.3	Tyre dimensions, rear		980	980	980	980
3.5	Number of wheels, front / rear (x = driven)					
3.6	Track width (centre of tyres), front	b10 (mm)				
3.7	Track width (centre of tyres), rear	b11 (mm)				
4.1	Mast tilt, forwards/backwards	∂/β °	6/10	6/10	6/10	6/10
4.2	Height with mast lowered (see tables)	h1 (mm)	2150	2150	2170	2300
4.3	Free lift (see tables)	h2 (mm)	140	140	145	145
4.4	Lift height (see tables)	h3 (mm)	3300	3300	3300	3300
4.5	Overall height with mast raised	h4 (mm)	4355	4355	4355	4355
4.7	Height to top of overhead guard	h6 (mm)	2145	2145	2165	2175
4.8	Seat height	h7 (mm)	940	940	990	990
4.12	Tow coupling height	h10 (mm)	310	310	330	340
4.19	Overall length	l1 (mm)	3555	3630	3805	3865
4.20	Length to fork face (includes fork thickness)	l2 (mm)	2485	2560	2735	2795
4.21	Overall width	b1/b2 (mm)	1150 / 1640	1150 / 1640	1275/1690	1290/1690
4.22	Fork dimensions (thickness, width, length)	s / e / l (mm)	40x100x1070	40x100x1070	45x125x1070	45x125x1070
4.23	Fork carriage to DIN 15 173 A/B/no		2A	2A	3A	3A
4.24	Fork carriage width	b3 (mm)	1000	1000	1000	1000
4.31	Ground clearance under mast, with load	m1 (mm)	115	115	135	150
4.32	Ground clearance at center of wheelbase, with load (forks lowered)	m2 (mm)	135	135	165	170
4.33	Working aisle width with 1000 x1200 mm pallets, crosswise	Ast (mm)	3855	3890	4075	4135
4.34	Working aisle width with 800 x1200 mm pallets, crosswise	Ast (mm)	3655	3690	3875	3935
4.34a	Working aisle width with 800 x1200 mm pallets, lengthwise	Ast (mm)	4055	4090	4275	4335
4.35	Turning circle radius	Wa (mm)	2200	2230	2380	2440
4.36	Minimum distance between centers of rotation	b13 (mm)	715	715	780	780
Performance						
5.1	Travel speed, with / without load	km / h	16.5/17.5	16.0/17.5	16.0/17.0	16.5/18.0
5.2	Lifting speed, with / without load	m / s	0.61 / 0.64	0.61 / 0.64	0.49 / 0.51	0.41 / 0.43
5.3	Lowering speed, with / without load	m / s	0.50 / 0.50	0.50 / 0.50	0.50 / 0.50	0.50 / 0.50
5.5	Rated drawbar pull, with / without load	N	16200/15900	16100/15800	15800/15800	14800/15000
5.6	Maximum drawbar pull, with / without load (5 min short duty)	N	-/-	-/-	-/-	-/-
5.7	Gradeability, with / without load	%	31/52	27/47	22/39	18/33
5.8	Maximum gradeability with / without load	%	-/-	-/-	-/-	-/-
5.9	Acceleration time (10 metres) with / without load	s	-/-	-/-	-/-	-/-
5.10	Service brakes (mechanical / hydraulic / electric / pneumatic)		Hydraulic	Hydraulic	Hydraulic	Hydraulic
IC Engine						
7.1	Manufacturer / Type		D04EG	D04EG	D04EG	D04EG
7.2	Rated / Nominal output to ISO 1585**	kW	36.0	36.0	36.0	36.0
7.3	Rated speed to DIN 70 020	rpm	2250	2250	2250	2250
7.4	Number of cylinders / cubic capacity	cm ³	4 / 3331	4 / 3331	4 / 3331	4 / 3331
7.6a	Max torque	Nm	177	177	177	177
7.7a	Max torque at engine speed	rpm	1800	1800	1800	1800
Miscellaneous						
8.1	Type of drive control		Powershift 1/1	Powershift 1/1	Powershift 1/1	Powershift 1/1
10.1	Maximum operating pressure for attachments	bar	180	180	180	180
10.2	Oil flow for attachments	l / min	75	75	73	73
10.7	Noise level, value at operator's ear (EN 12053)	dB (A)	78	78	78	78
10.8	Towing coupling design / DIN type, ref.		Pin	Pin	Pin	Pin

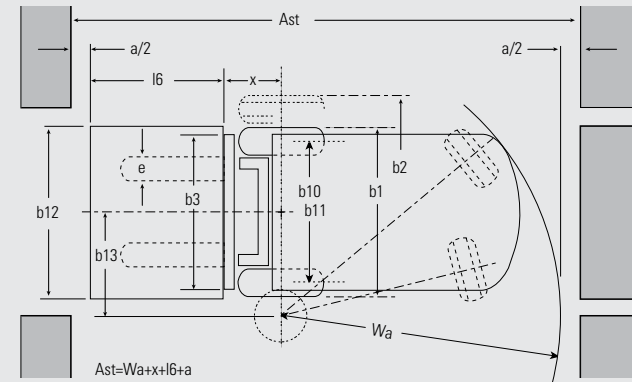
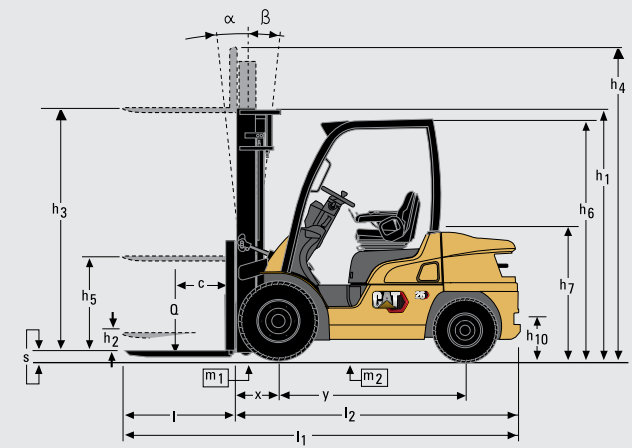

$$Ast = Wa + x + l6 + a$$

Ast = Working aisle width with load

a = Safety clearance (200 mm)

l6 = Pallet length (800 or 1000 mm)

b12 = Pallet width (1200 mm)

Characteristics		
1.1	Manufacturer (abbreviation)	
1.2	Manufacturer's model designation	
1.3	Power source: (battery, diesel, LPG, petrol)	
1.4	Operator type: pedestrian, (operator) - standing, - seated	
1.5	Load capacity	Q (kg)
1.6	Load centre distance	c (mm)
1.8	Load distance, axle to fork face	x (mm)
1.9	Wheelbase	y (mm)
Weight		
2.1	Truck weight, without load / including battery (simplex mast, lowest lift height)	kg
2.2	Axle loading with maximum load, front / rear (simplex mast, lowest lift height)	kg
2.3	Axle loading without load, front / rear (simplex mast, lowest lift height)	kg
Wheels, Drive Train		
3.1	Tyres: V = solid, L = pneumatic, SE = solid pneumatic - front / rear	
3.2	Tyre dimensions, front	
3.3	Tyre dimensions, rear	
3.5	Number of wheels, front / rear (x = driven)	
3.6	Track width (centre of tyres), front	b10 (mm)
3.7	Track width (centre of tyres), rear	b11 (mm)
Dimensions		
4.1	Mast tilt, forwards/backwards	∂/β °
4.2	Height with mast lowered (see tables)	h1 (mm)
4.3	Free lift (see tables)	h2 (mm)
4.4	Lift height (see tables)	h3 (mm)
4.5	Overall height with mast raised	h4 (mm)
4.7	Height to top of overhead guard	h6 (mm)
4.8	Seat height	h7 (mm)
4.12	Tow coupling height	h10 (mm)
4.19	Overall length	l1 (mm)
4.20	Length to fork face (includes fork thickness)	l2 (mm)
4.21	Overall width	b1/b2 (mm)
4.22	Fork dimensions (thickness, width, length)	s / e / l (mm)
4.23	Fork carriage to DIN 15 173 A/B/no	
4.24	Fork carriage width	b3 (mm)
4.31	Ground clearance under mast, with load	m1 (mm)
4.32	Ground clearance at center of wheelbase, with load (forks lowered)	m2 (mm)
4.33	Working aisle width with 1000 x1200 mm pallets, crosswise	Ast (mm)
4.34	Working aisle width with 800 x1200 mm pallets, crosswise	Ast (mm)
4.34a	Working aisle width with 800 x1200 mm pallets, lengthwise	Ast (mm)
4.35	Turning circle radius	Wa (mm)
4.36	Minimum distance between centers of rotation	b13 (mm)
Performance		
5.1	Travel speed, with / without load	km / h
5.2	Lifting speed, with / without load	m / s
5.3	Lowering speed, with / without load	m / s
5.5	Rated drawbar pull, with / without load	N
5.6	Maximum drawbar pull, with / without load (5 min short duty)	N
5.7	Gradeability, with / without load	%
5.8	Maximum gradeability with / without load	%
5.9	Acceleration time (10 metres) with / without load	s
5.10	Service brakes (mechanical / hydraulic / electric / pneumatic)	
IC Engine		
7.1	Manufacturer / Type	
7.2	Rated / Nominal output to ISO 1585**	kW
7.3	Rated speed to DIN 70 020	rpm
7.4	Number of cylinders / cubic capacity	cm ³
7.6a	Max torque	Nm
7.7a	Max torque at engine speed	rpm
Miscellaneous		
8.1	Type of drive control	
10.1	Maximum operating pressure for attachments	bar
10.2	Oil flow for attachments	l / min
10.7	Noise level, value at operator's ear (EN 12053)	dB (A)
10.8	Towing coupling design / DIN type, ref.	

Cat Lift Trucks	Cat Lift Trucks	Cat Lift Trucks	Cat Lift Trucks	Cat Lift Trucks	Cat Lift Trucks	Cat Lift Trucks
GP15N	GP18N	GP20CN	GP20N	GP25N	GP30N	GP35N
LPG	LPG	LPG	LPG	LPG	LPG	LPG
Seated	Seated	Seated	Seated	Seated	Seated	Seated
1500	1750	2000	2000	2500	3000	3500
500	500	500	500	500	500	500
400	400	415	455	460	495	495
1400	1400	1400	1600	1600	1700	1700
2490	2690	3010	3300	3600	4240	4630
3510/460	3870/540	4320/660	4600/670	5390/680	6470/770	7180/950
1040/1430	990/1670	1010/1970	1410/1860	1390/2180	1710/2530	1630/3000
SE / SE	SE / SE	SE / SE	SE / SE	SE / SE	SE / SE	SE / SE
6.50-10-10PR	6.50-10-10PR	6.50-10 / 5.00	7.00-12-12PR	7.00-12-12PR	28x9-15-12PR	250-15-12PR
5.00-8-8PR	5.00-8-8PR	5.00-8/3.00	6.00-9-10PR	6.00-9-10PR	6.50-10-10PR	6.50-10-10PR
2x / 2	2x / 2	2x / 2	2x / 2	2x / 2	2x / 2	2x / 2
890	890	890	960	960	1060	1060
900	900	900	980	980	980	980
6/10	6/10	6/10	6/10	6/10	6/10	6/10
2140	2140	2140	2150	2150	2170	2300
115	115	115	140	140	145	145
3300	3300	3300	3300	3300	3300	3300
4355	4355	4355	4355	4355	4355	4355
2140	2140	2140	2145	2145	2165	2175
930	930	930	940	940	990	990
290	290	290	310	310	330	340
3330	3370	3425	3555	3630	3805	3865
2260	2300	2355	2485	2560	2735	2795
1065/-	1065/-	1065/-	1150 / 1640	1150 / 1640	1275/1690	1290/1690
35x100x1070	35x100x1070	35x100x1070	40x100x1070	40x100x1070	45x125x1070	45x125x1070
2A	2A	2A	2A	2A	3A	3A
920	920	920	1000	1000	1000	1000
110	110	110	115	115	135	150
135	135	135	135	135	165	170
3550	3580	3635	3855	3890	4075	4135
3350	3380	3435	3655	3690	3875	3935
3750	3780	3835	4055	4090	4275	4335
1950	1980	2020	2200	2230	2380	2440
555	555	555	715	715	780	780
19.0/19.5	19.0/19.5	19.0/19.5	19.0/19.5	19.0/19.5	19.0/19.5	16.5/18.0
0.64 / 0.65	0.64 / 0.65	0.64 / 0.65	0.59 / 0.61	0.59 / 0.61	0.52 / 0.53	0.43 / 0.44
0.52 / 0.50	0.52 / 0.50	0.52 / 0.50	0.50 / 0.50	0.50 / 0.50	0.53 / 0.50	0.42 / 0.40
17400/16900	17400/16800	17300/17100	17100/16800	17100/16700	21800/21400	19900/19800
-/-	-/-	-/-	-/-	-/-	-/-	-/-
49/93	43/81	37/70	35/60	30/53	32/60	26/48
-/-	-/-	-/-	-/-	-/-	-/-	-/-
-/-	-/-	-/-	-/-	-/-	-/-	-/-
Hydraulic	Hydraulic	Hydraulic	Hydraulic	Hydraulic	Hydraulic	Hydraulic
GK21E	GK21E	GK21E	GK21E	GK21E	GK25E	GK25E
41.0	41.0	41.0	41.0	41.0	46.9	46.9
2700	2700	2700	2700	2700	2700	2700
4 / 2065	4 / 2065	4 / 2065	4 / 2065	4 / 2065	4 / 2488	4 / 2488
151	151	151	151	151	188	188
1800	1800	1800	1800	1800	1600	1600
Powershift 1/1	Powershift 1/1	Powershift 1/1	Powershift 1/1	Powershift 1/1	Powershift 1/1	Powershift 1/1
180	180	180	180	180	180	180
60	60	60	73	73	73	73
79	79	79	79	79	79	79
Pin	Pin	Pin	Pin	Pin	Pin	Pin

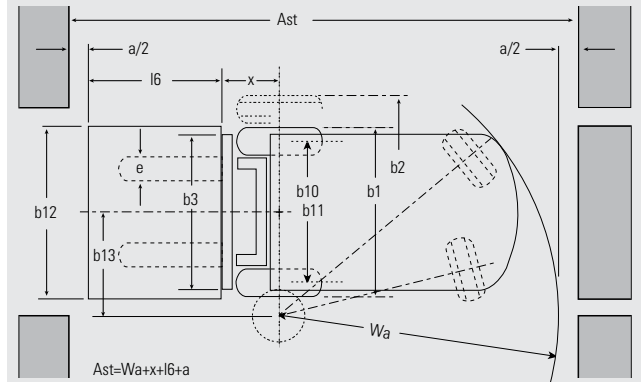
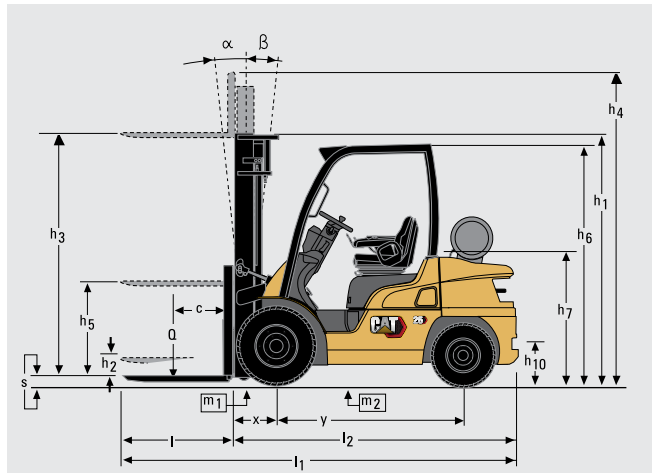

$Ast = Wa + x + l6 + a$

$Ast = Wa + x + l6 + a$

- Ast = Working aisle width with load
- a = Safety clearance (200 mm)
- l6 = Pallet length (800 or 1000 mm)
- b12 = Pallet width (1200 mm)

GP15N-GP18N				GP15N		GP18N	
Mast Type	h3	h1	h4	h2/h5	Q @ c=500mm kg	h2/h5	Q @ c=500mm kg
	mm	mm	mm				
Simplex	3000	1990	4055	80	1500	80	1750
	3300	2140	4355	80	1500	80	1750
	3500	2240	4555	80	1500	80	1750
	3700	2340	4755	80	1500	80	1750
	4000	2540	5055	80	1500	80	1750
	4500	2790	5555	80	1425 *	80	1650 *
	5000	3050	6055	80	1325 *	80	1600 *
	5500	3300	6555	80	1250 *	80	1525 *
	6000	3550	7055	80	1200 *	80	1325 *
	Duplex	3000	1995	4055	940	1500	940
3290		2140	4350	1085	1500	1085	1750
3510		2260	4570	1205	1500	1205	1750
4030		2585	5085	1530	1500	1530	1750
Triplex		3700	1790	4755	735	1500	735
	4000	1890	5055	835	1450	835	1725
	4300	1990	5355	935	1425	935	1675 *
	4700	2140	5755	1085	1350 *	1085	1625 *
	5000	2240	6055	1185	1300 *	1185	1575 *
	5500	2430	6555	1375	1250 *	1375	1500 *
	6000	2610	7055	1555	1175 *	1555	1325 *
	6500	2850	7555	1795	950 *	1795	950 *
	7000	3050	8055	1995	650 *	1995	650 *

DP/GP20N(3)-DP/GP25N(3)				DP/GP20N(3)		DP/GP25N(3)	
Mast Type	h3	h1	h4	h2/h5	Q @ c=500mm kg	h2/h5	Q @ c=500mm kg
	mm	mm	mm				
Simplex	3000	1995	4055	100	2000	100	2500
	3300	2145	4355	100	2000	100	2500
	3500	2245	4555	100	2000	100	2500
	3700	2345	4755	100	2000	100	2500
	4000	2545	5055	100	2000	100	2500
	4500	2795	5555	100	1950	100	2450 *
	5000	3065	6055	100	1900 *	100	2350 *
	5500	3315	6555	100	1850 *	100	2250 *
	6000	3565	7055	100	1800 *	100	2150 *
	Duplex	3000	1995	4055	940	2000	940
3300		2145	4350	1090	2000	1090	2500
3530		2265	4585	1210	2000	1210	2500
4020		2590	5075	1535	2000	1535	2500
Triplex		3700	1795	4755	740	2000	740
	4000	1895	5055	840	2000	840	2500
	4300	1995	5355	940	1950	940	2450
	4700	2145	5755	1090	1900	1090	2350 *
	5000	2245	6055	1190	1850 *	1190	2300 *
	5500	2415	6555	1360	1800 *	1360	2200 *
	6000	2585	7055	1530	1750 *	1530	2100 *
	6500	2795	7555	1740	1650 *	1740	1750 *
	7000	3065	8055	2010	1250 *	2010	1250 *

DP/GP30N(3)					
Mast Type	h3	h1	h4	h2/h5	Q @ c=500mm kg
	mm	mm	mm		
Simplex	3000	2015	4055	95	3000
	3300	2165	4355	95	3000
	3500	2265	4555	95	3000
	3700	2365	4755	95	3000
	4000	2565	5055	95	3000
	4500	2815	5555	95	2950
	5000	3115	6055	95	2850
	5500	3365	6555	95	2750
	6000	3615	7055	95	2400 *
	Duplex	3000	2045	4055	990
3250		2165	4305	1110	3000
3490		2285	4545	1230	3000
4010		2610	5065	1555	3000
Triplex		3700	1815	4755	760
	4000	1915	5055	860	3000
	4300	2015	5355	960	3000
	4700	2165	5755	1110	2900
	5000	2265	6055	1210	2800
	5500	2435	6555	1380	2750
	6000	2605	7055	1550	2400 *
	6500	2815	7555	1760	1750 *
	7000	3115	8055	2060	1250 *

DP/GP35N(3)					
Mast Type	h3	h1	h4	h2/h5	Q @ c=500mm kg
	mm	mm	mm		
Simplex	3000	2130	4055	95	3500
	3300	2280	4355	95	3500
	3500	2380	4555	95	3500
	3700	2480	4755	95	3500
	4000	2680	5055	95	3500
	4500	2930	5555	95	3500
	5000	3230	6055	95	3400 *
	5500	3480	6555	95	3200 *
	6000	3730	7055	95	2400 *
	Duplex	3010	2180	4065	1125
3300		2300	4355	1245	3500
3500		2445	4555	1390	3500
4000		2765	5055	1710	3500
Triplex		3700	1930	4755	875
	4000	2030	5055	975	3500
	4300	2130	5355	1075	3500
	4700	2280	5755	1225	3450
	5000	2380	6055	1325	3350
	5500	2550	6555	1495	3200 *
	6000	2720	7055	1665	2400 *
	6500	2930	7555	1875	1750 *
	7000	3230	8055	2175	1250 *

GP20CN						
Mast Type	h3	h1	h4	h2/h5	Q @ c=500mm kg	
	mm	mm	mm			mm
Simplex	3000	1990	4055	80	2000	
	3300	2140	4355	80	2000	
	3500	2240	4555	80	2000	
	3700	2340	4755	80	2000	
	4000	2540	5055	80	2000	
	4500	2790	5555	80	1950	
	5000	3050	6055	80	1400	
	Duplex	3000	1995	4055	940	2000
		3290	2140	4350	1085	2000
		3510	2260	4570	1205	2000
4030		2585	5085	1530	2000	
Triplex		3700	1790	4755	735	2000
	4000	1890	5055	835	2000	
	4300	1990	5355	935	1950	
	4700	2140	5755	1085	1900	
	5000	2240	6055	1185	1325	

GP15-20CN

All dimensions include load backrest. In case load backrest is not used h5 will increase by 410 mm, while h4 will decrease by 410 mm.

DP/GP20-35N(3)

All dimensions include load backrest. In case load backrest is not used h5 will increase by 390 mm (20N(3), 25N(3)), 350 mm (30N(3)), 240 mm (35N(3)), while h4 will decrease by 390 mm (20N(3), 25N(3)), 350 mm (30N(3)), 240 mm (35N(3)).

The capacities are applicable for pneumatic shaped solid tyres (SE).

* Capacities shown require truck equipped with dual tyres. Consult your dealer for the maximum back tilt allowed, to obtain the capacities specified.

Mast Performance and Capacity

- h1 Height with mast lowered
- h2 Standard free lift
- h3 Lift height
- h4 Height with mast raised
- h5 Full free lift
- Q Lifting capacity, rated load
- c Load centre (distance)

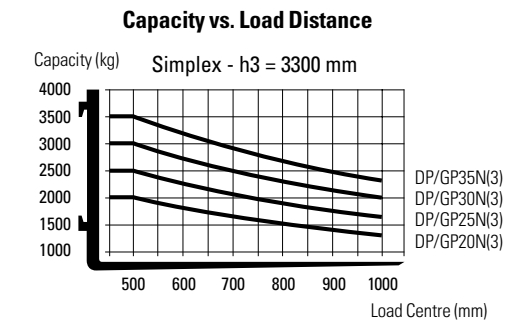
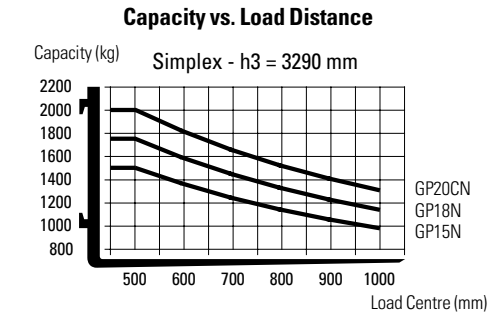

info@catlifttruck.com | www.catlifttruck.com

CESC2289(03/24) © 2024 MLE B.V. (registration no. 33274459). All rights reserved. CAT, CATERPILLAR, LET'S DO THE WORK, their respective logos, "Caterpillar Yellow", the "Power Edge" and Cat "Modern Hex" trade dress as well as corporate and product identity used herein, are trademarks of Caterpillar and may not be used without permission.

NOTE: Performance specifications may vary depending on standard manufacturing tolerances, vehicle condition, types of tyres, floor or surface conditions, applications, or operating environment. Trucks may be shown with non-standard options. Specific performance requirements and locally available configurations should be discussed with your Cat lift trucks Dealer. Cat Lift Trucks follows a policy of continual product improvement. For this reason, some materials, options and specifications could change without notice.



DOWNLOAD
BROCHURE



WATCH
VIDEOS



DOWNLOAD
OUR APP

