

**Weights**

Operating weight with canopy and bucket (ISO 6016)	1711 kg
Transport mass (no attachment)	1594 kg
Additional weight for cab with heating	96 kg
Additional weight for long dozer blade	9 kg
Ground pressure with rubber tracks	29.40 kPa

**Engine**

Make / model	Yanmar / 3TNV74F-SPBC (Stage V)
Fuel	Diesel
Number of cylinders	3
Displacement	993 cm <sup>3</sup>
Maximum power @ 2400 rpm (ISO 14396)	11.0 kW
Maximum torque @ 1800 rpm (SAE J1995)	50.2 Nm

**Hydraulic System**

Pump type	Triple gear pump
Pump capacity	32.50 L/min
Auxiliary flow	32.50 L/min
Auxiliary relief	227.0 bar

**Performance**

Digging force, dipperstick (ISO 6015)	9108 N
Digging force, bucket (ISO 6015)	16177 N
Drawbar pull	14334 N
Travel speed, low range	2.1 km/h
Travel speed, high range	4.3 km/h

**Slew System**

Boom swing, left	80.0°
Boom swing, right	60.0°
Slew rate	8.7 RPM

**Fluid Capacities**

Fuel reservoir	19.00 L
Hydraulic reservoir	13.90 L

**Environmental**

Noise level LpA(EU Directive 2006/42/EC)	79 dB(A)
Noise level LWA(EU Directive 2000/14/EC)	93 dB(A)
Whole body vibration (ISO 2631-1)	0.33 ms <sup>-2</sup>
Hand-arm vibration (ISO 5349-1)	0.51 ms <sup>-2</sup>

**Standard Features**

230 mm rubber track	Hydraulic and travel control lockout
980 mm dozer blade with two 190 mm blade extensions	Hydraulic joystick controls
Battery disconnect switch	Hydraulically retractable undercarriage from 1360 mm to 980 mm
Control console locks	980 mm
Cupholders	Retractable seat belt
Double acting auxiliary hydraulics	Storage compartment
Engine monitor with auto shutdown	TOPS/ROPS/FOPS canopy <sup>1</sup>
Exposed counterweight with 4 mm steel tailgate	Upper structure four point tie down
Foldable and ergonomic travel pedals	Water separator
Full fuel warning alarm	Work light (boom)
Horn	Warranty: 24 months, 2000 hours (whichever occurs first)

1. Roll Over Protective Structure (ROPS) – Meets requirements of ISO 3471. Tip Over Protective Structure (TOPS) – Meets requirements of ISO 12117. Falling Object Protective Structure (FOPS) - Meets requirements of ISO 3449.

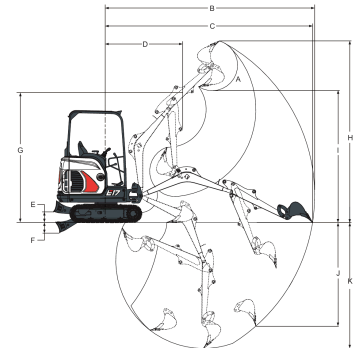
**Working Range**

(A)	196.0°	(G)	2405.0 mm
(B)	3919.0 mm	(H)	3371.0 mm
(C)	3871.0 mm	(I)	2370.0 mm
(D)	1526.0 mm	(J)	1810.0 mm
(E)	220.0 mm	(K)	2249.0 mm
(F)	204.0 mm		

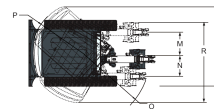
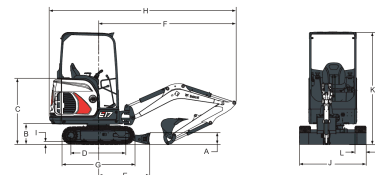
**Dimensions**

(A)	235.0 mm	(J*)	1360.0 mm
(B)	419.0 mm	(K)	2299.0 mm
(C)	1340.0 mm	(L)	230.0 mm
(D)	1114.0 mm	(M)	433.0 mm
(E)	1045.0 mm	(N)	589.0 mm
(F)	2666.0 mm	(O)	1128.0 mm
(G)	1476.0 mm	(P)	1009.0 mm
(H)	3665.0 mm	(Q)	1801.0 mm
(I)	25.0 mm	(R)	1645.0 mm
(J)	980.0 mm		

**Options**

Demolition package (boom, arm, bucket cylinder covers & HD travel hoses guard)	Additional halogen lights
Object handling package (Valves, OWD, Lifteye)	Beacon
TOPS/ROPS cab w/ heater	Dlx textile suspension seat
Long dozer blade	Special application kit
AUX1 direct return to tank	L/R mirrors
AUX1 on arm	Fire extinguisher
Keyless ignition	Klacc C and MS01 couplers
Travel motion alarm	Grease Gun w/ holder
AM/FM MP3 radio	