

MANIACCESS

■ 180 ATJ

- Working height : 17.65 m
- Max. outreach : 10.60 m
- S.W.L : 230 kg
- Diesel engine 45 HP
- Turret rotation : 350°
- 4 simultaneous movements
- 4 wheel drive
- 4 wheel steer
- Crab steer

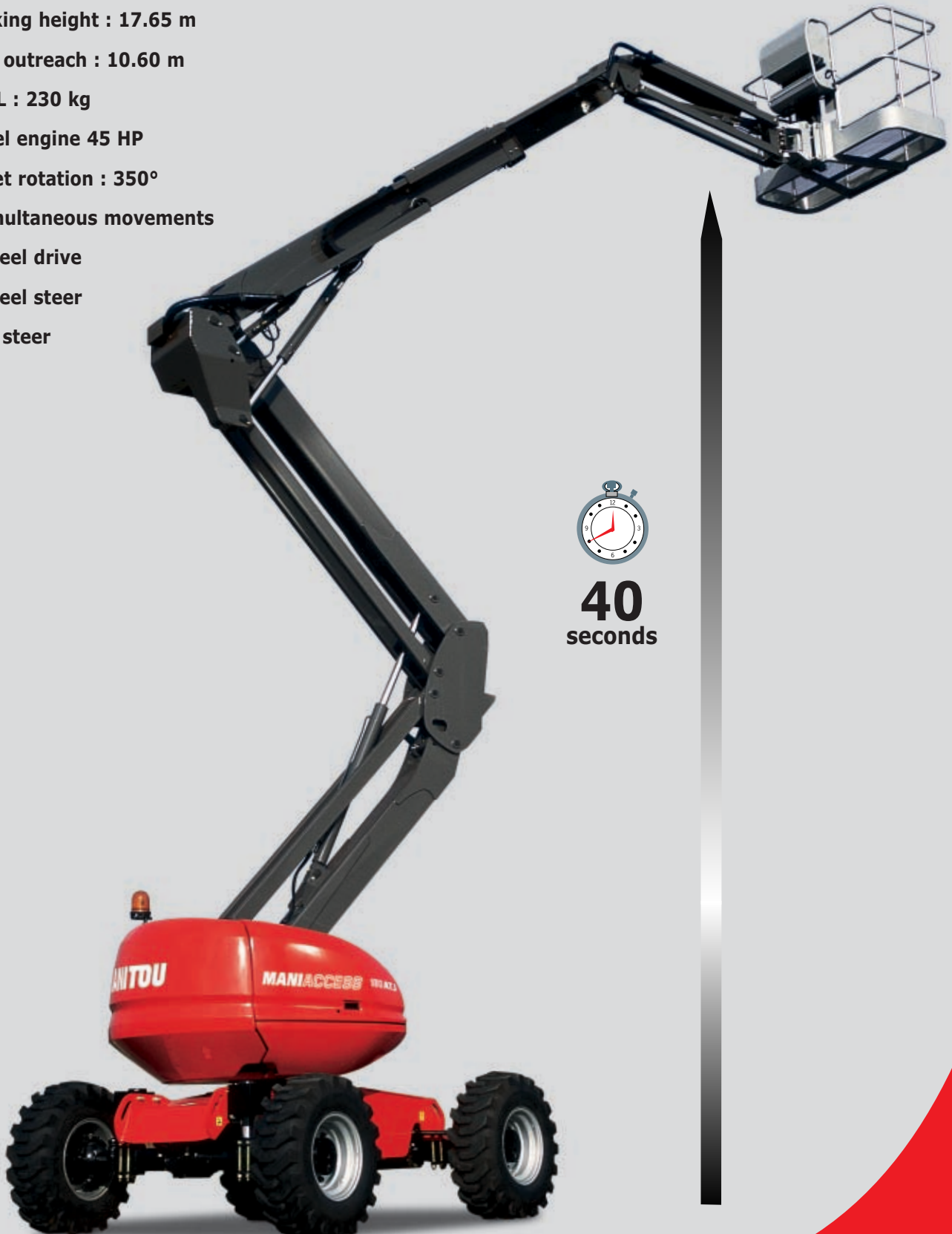

40
seconds

180 ATJ

S.W.L.230 kg including 2 people
External use :wind 45 km/h

Working height17.65 m
Platform floor height15.65 m

Max. outreach10.60 m
Up and over clearance7.15 m
Overall length7.77 m
Length (transport position)5.77 m
Overall width2.30 m
Overall height2.37 m
Basket size1.80 m x 0.80 m
Ground clearance42.5 cm
Turning radius ins/outside1.32/3.66 m

Turret rotation350°
Basket rotation180°
Jib movement140°

Engine (Low emission)
 PERKINS 404C2245 HP

Maxi. travel speed6 km/h
Lifting time40 s

Gradeability on rough terrain40 %
Max. slope accepted5° or 9%

Hydraulic tank54 l.
Diesel tank52 l.

Tyres12.5 - 18
 4 wheel drive/4 wheel steer/crab steer

Weight8090 kg

Standard equipment

- Proportional controls
- 4 simultaneous movements
- Foam filled tyres
- Differential lock
- Limited front axle slip
- Diagnostic tools
- Hour meter
- Klaxon
- Rotating beacon
- Slope and overload alarm in the basket
- Overslope unlocking
- Lifting brackets
- Safety electric pump
- 230 V auxiliary power cable

Options

- **Oscillating axle**
- **Continuous rotation**
- **On board generator set**
- Electric plug in platform (230V)
- Air predisposal in the platform
- Water predisposal in the platform
- Working lights
- Customised Painting
- Cold conditions -25°C
- Biodegradable oil
- All motion alarm
- Drive alarm
- Safety harness

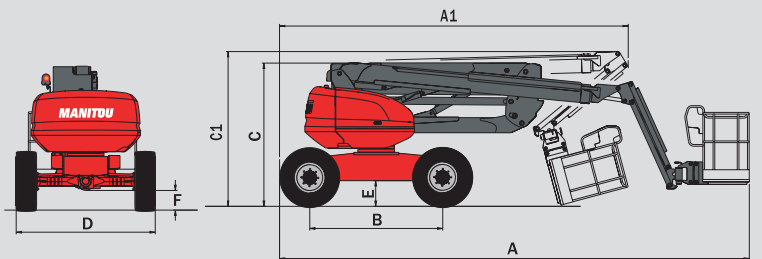
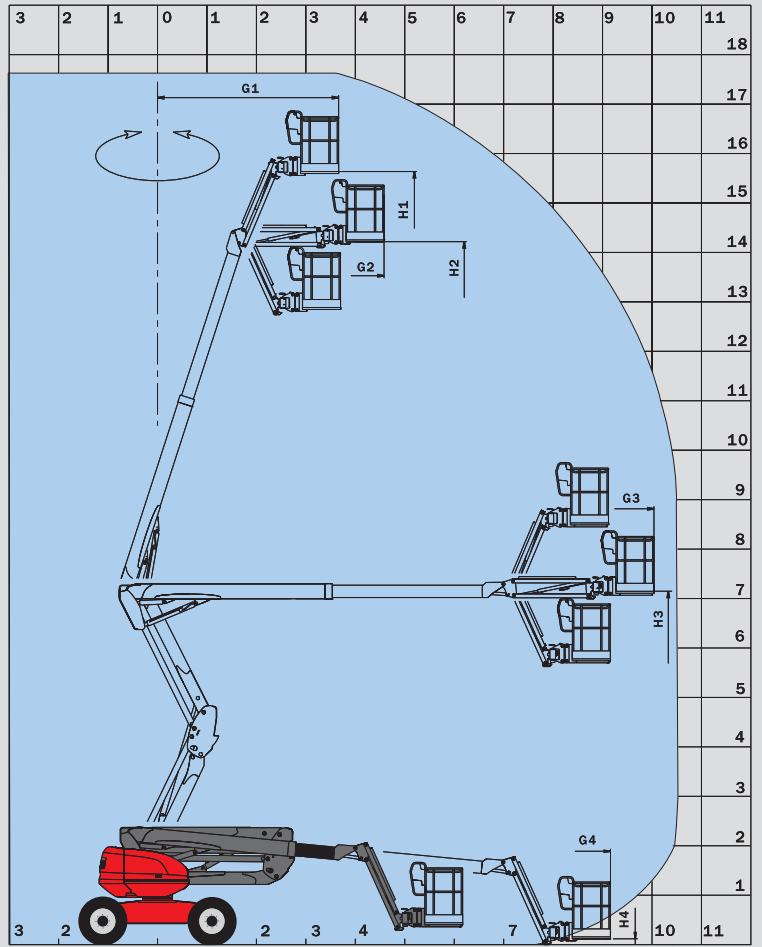

A	7775
A1	5770
B	2200
C	2370
C1	2560
D	2300
E	425
F	325
G	1325
G1	3660
G2	4580
G3	10040
G4	9160
H	3665
H1	15700
H2	14250
H3	7150
H4	120
I	4530
J	6875
K	2730

mm

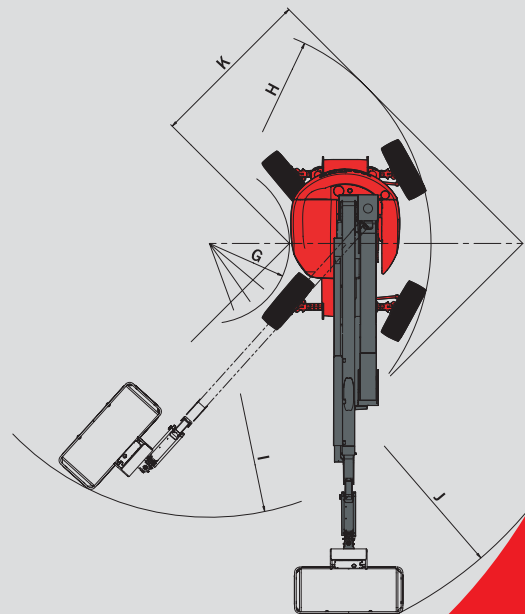

This publication in no way constitutes an offer and the company reserves the right to alter specification without prior notice.
 The MANITOU models presented in this brochure can be supplied complete with optional equipment attachments.



MANITOU BF SA

B.P. 249 - 44158 Ancenis Cedex - France
 Tél. : 33 2 40 09 10 11 / Export Department Fax : 33 2 40 09 10 97
 www.manitou.com

700183EN

