

6 Tonne Powerswivel

MACH666

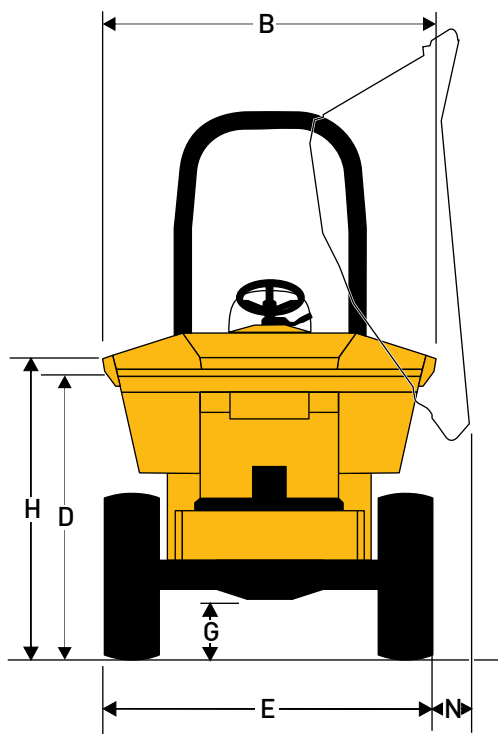
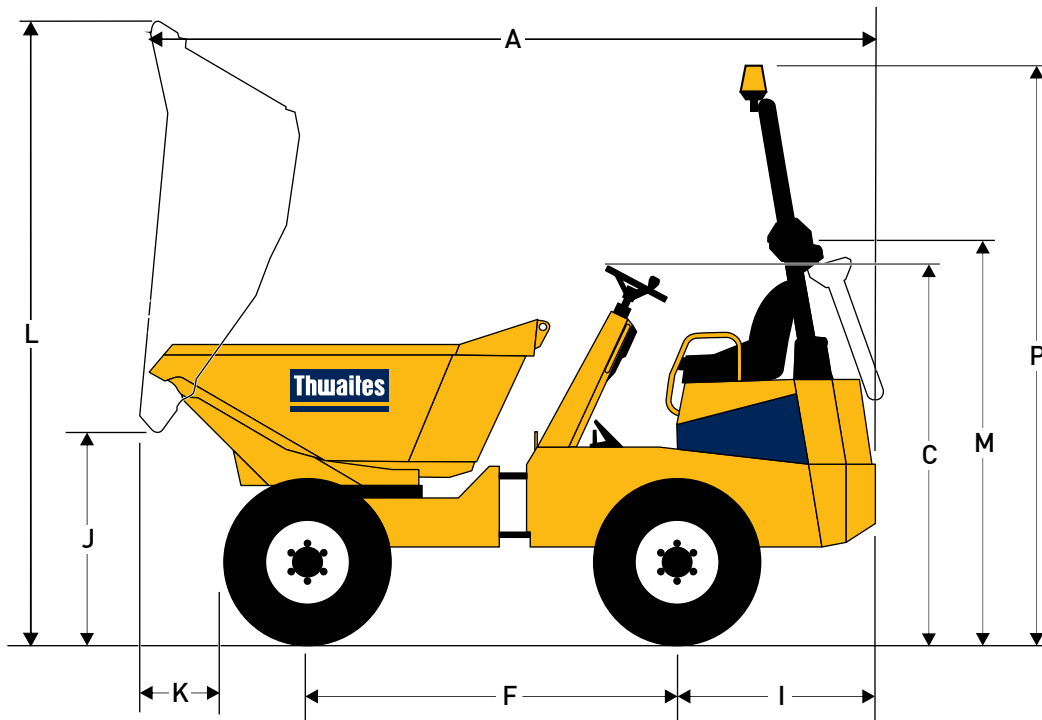

Dimensions (mm)

| | |
|---|------|
| A | 4780 |
| B | 2280 |
| C | 2230 |
| D | 1670 |
| E | 2240 |
| F | 2480 |
| G | 370 |
| H | 1850 |
| I | 1200 |
| J | 1100 |
| K | 550 |
| L | 3694 |
| M | 2230 |
| N | 100 |
| P | 3300 |

6 Tonne Powerswivel

MACH666

| | | |
|-------------------|---------------|-------------|
| Capacities | Max safe load | 6000kg |
| | Heaped | 3150 litres |
| | Struck | 2550 litres |
| | Water | 1650 litres |

Engine

Perkins 1104 D series, 70kW/94 bhp (gross) at 2200 rpm, 4-cylinder turbo-charged water-cooled direct-injection diesel. Max. torque 392 Nm (289 lb ft). Hour meter, battery isolation switch and heavy-duty cyclonic air cleaner positioned within the lockable engine compartment. Tier 3-/Stage IIIA-compliant.

Noise Levels

Operator's ear 84 LpA, airborne sound power level 102 LwA (to 2000/14/EC).

Transmission

Torque convertor four speed forward and reverse powershuttle transmission with column-mounted directional control lever. With heavy duty gear driven transfer box.

| | | |
|---------------|---------------------|---------------------|
| Speeds | Forward and Reverse | |
| | 1 | 5.0km/h (3.1 mph) |
| | 2 | 8.0km/h (5.0 mph) |
| | 3 | 15.1km/h (9.3 mph) |
| | 4 | 27.7km/h (17.2 mph) |

| | |
|--------------|-------------------------|
| Tyres | 405/70 x 20 |
| | Load/Speed Index 142 A8 |
| | Track grip tread |

Brakes and Axles

Twin circuit totally enclosed multiplate oil immersed discs, mounted on both axles with automatic adjustment for wear. Hand operated parking brake. Heavy duty axles with epicyclic reduction and fully floating half shafts.

Kinglink Chassis

Front and rear chassis constructed from deep section folded steel plate, with three point Kinglink giving articulation and oscillation for better stability, traction and extra safety on site. Remote greasing point provided for lubrication of top Kinglink articulation pin.

Skip

Hydraulically operated, 8 mm steel base plate, fully welded, mouth and sides of skip reinforced with box section giving greater strength to minimise skip damage. No material traps. Powerswivel mounted on a ball bearing turntable with powered rotation through 180° by means of twin slewing cylinders, operated by a single dual-axis control lever. Automatic safety lock holds skip in central position when travelling.

Seating & Controls

Adjustable suspension seat, accessible from both sides. Audible warning device for handbrake in "on" position. Electric horn. Large pedal pads with handbrake and hydraulic controls ready to hand. Super-bright warning lights for all critical functions.

Service Access

Lockable three sided cover opens to provide easy access from ground level to engine service points, all located on the same side. Rear chassis panel can be hinged back on retainers. An additional service access door incorporates the battery. Moulded diesel and hydraulic tanks positioned low in chassis side members, permitting access to the filler caps from ground level.

Electrics

Wiring harness contained within conduits and all electrical components water resistant to IP65/67 standards.

Steering and Hydraulics

Single gear pump providing hydraulic functions includes priority power steering. Filter mounted on top of the tank accessible from ground level. Hydraulic test point fitted as standard.

| | | |
|------------------------|-----------|-----------|
| Tank Capacities | Fuel | 70 litres |
| | Hydraulic | 70 litres |

| | |
|----------------------|------------------------------------|
| Shipping Cube | 24.2 m ³ (without ROPS) |
|----------------------|------------------------------------|

| | |
|-----------------------|--------|
| Unladen Weight | 4280kg |
|-----------------------|--------|

| | |
|---------------------------|-----|
| Clearance Diameter | 12m |
|---------------------------|-----|

| | |
|-----------------------|----------|
| Towing Bracket | Standard |
|-----------------------|----------|

ROPS

For the UK and other markets where it is a legal requirement a fully approved folding ROPS frame is fitted as standard.

Optional Extras

ROPS/FOPS frame and canopy. Beacon. Full road lighting equipment. UK road equipment. Anti-theft device.

Distributor



Thwaites Ltd. Leamington Spa, Warwickshire CV32 7NQ, England
 Tel +44 (0)1926 422471 Fax +44 (0)1926 337155
 www.thwaitesdumpers.co.uk



We reserve the right to change all specifications without prior notice.
 Printed in England 02/2017